



ARS33-M060.22 K5S1

Manual tool change

Item no. **10200051**

HF-Spindle for dressing of grinding wheels

Bearings

Steel ball bearing (pcs)	2
Lifetime lubricated	maintenance free

Motor

Motor technology	3-phase asynchronous drive (no brushes or sensors)
Frequency	1.000 Hz
Motor poles (pairs)	1
Rated rotation speed	60.000 rpm
Acceleration/braking value	10.000 rpm
Per second	(other values by consultation)

Power values

Uncooled

	Pmax / 5 s	S6-60%	S1-100%	
Rated power	0,24	0,24	0,18	[kW]
Voltage	46	46	44	[V]
Current	6,5	6,5	5,5	[A]

ARS33-M060.22 K5S1

Manual tool change
Item no. **10200051**

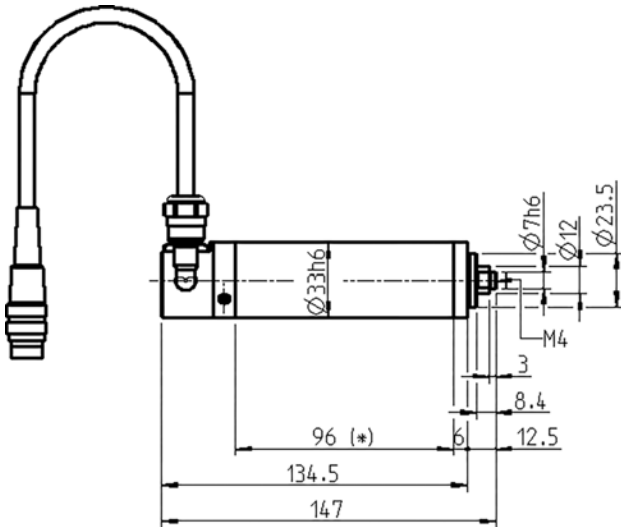

Dimensions

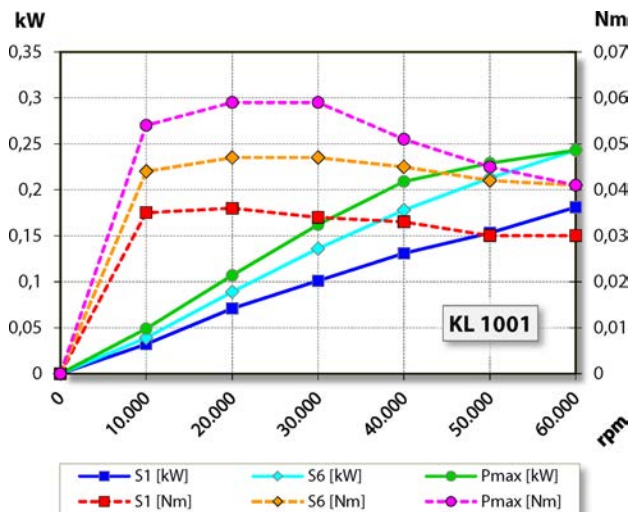

Performance Diagram

Uncooled

Measurement of power is funded by in-house testing.

Characteristics

Housing	Aluminium
Housing diameter	33 mm
Cooling	Uncooled
Heat dissipation	Via the spindle holder
Housing temperature	< + 45° C
Ambient temperature	+ 10°C ... + 45°C
Sealing air	
Protection category (sealing air turned on)	IP54
Tool change	Manual tool change
Tool Holder	Grinding wheel maximum dia. 20 mm maximum t = 4 - 6 mm
Clamping range	Ø 7h6 - M4
Clockwise	
Connector plug	3-pin (Amphenol C 091 A) Cable length 5 m
Weight	~ 0,65 kg
Axial run-out of mounting surface	< 1 µ